

【 Alpha 1S 】 v2.0

# User Manual



Scan the QR code to  
download the APP



Available from:

[www.ubtrobot.com](http://www.ubtrobot.com)



UBTECH Robotics Corp.

[www.ubtrobot.com](http://www.ubtrobot.com)



Find us on facebook



## Safety Instructions

Dear User, Congratulations! You are now the official owner of Alpha, the intelligent robot. Before using Alpha, please read this manual carefully and scan the QR code to download the control App.

1. Children under the age of 14 should be supervised by an adult.
2. To avoid personal injury or damage to Alpha, do not insert your fingers or any other foreign objects into his joints or connectors.
3. Alpha needs your constant love and attention, so remember to treat him with care.
4. Never assemble or disassemble Alpha on your own. For repairs, please contact qualified service personnel. (Refer to the "Customer Support" page on the back of the cover.)
5. Keep Alpha away from your face and eyes as well as from small children.
6. Remember, Alpha is not waterproof, and you should always keep him away from an open flame.
7. Please operate Alpha on smooth surfaces, as uneven surfaces, inclining or wet floors, or areas with obstacles may stall him or cause him to fall.
8. When programming actions and debugging, if Alpha's joints become twisted due to improper programming, please shut down and turn off the power supply immediately as to avoid further damage.

9. The servos (motors) powering Alpha's joints are precision products. Please avoid all actions that will lead to external shock.
10. When Alpha is moving or performing an action, do not move his joints with force to prevent unnecessary wear and tear.
11. Please avoid damaging Alpha by dropping him or causing him to fall. Whenever he is moving or performing an action, try to provide him with necessary space and effective protection. Do not use Alpha on the edge of a table, stairway, or in any location that may lead to him to fall down or become damaged. We do not offer a free repair service for cases when Alpha is dropped or falls down from heights.
12. Gears within the servos are removable and consumable materials. After long or excessive use, replacements must be installed. We suggest you limit your Alpha use to no more than 1 hour per session. Alpha needs a break too!
13. The charging time for the battery is approximately two hours. Only use the included charger or a charger specifically designed for Alpha.
14. Stop using Alpha when the servos overheat and resume once the temperature is normal again.
15. Please avoid touching Alpha when he is in use.

**!** If any of the following circumstances occur, please shut off the power immediately and contact our customer service team:

- a. Alpha emits smoke or smells.
- b. Water or other foreign objects penetrate Alpha.
- c. Alpha becomes damaged.

## **Important:**

- ① Mobile APP helps you better operate the Robot. Please scan the QR code on the user manual cover, or search "Alpha 1S" in Apple APP Store and Google Play to download and install the APP.
- ② You can program the robot to create new movements with PC software designed for Alpha 1S. The PC software can be downloaded from the "Service & Technology" page of the UBTECH Robotics website <http://www.ubtrobot.com>.
- ③ For software user manual and other technical support, please go to "Service & Technology" page of <http://www.ubtrobot.com>.

**This packaging contains useful information  
Please keep it!**



01

# Package Contents

Robot

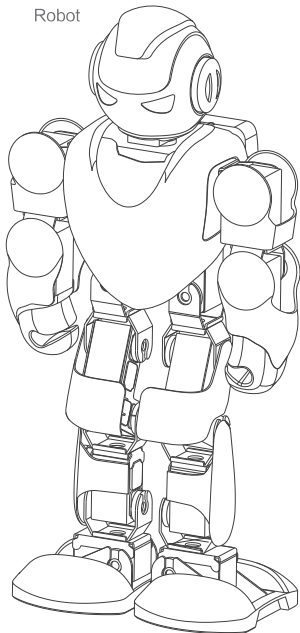

Product parameters	
Product dimension:	418x198x109(mm)
Product weight:	1.63kg
Working voltage:	DC6.8V ~ DC9.6V(Standard: 7.4V)
Working current:	1A ~ 3A
Battery capacity:	2200mAh
Audio:	8Ω 2W
Connection:	
1) Mini USB port: USB 2.0	
2) Micro SD card port: 128MB ~ 16GB	
3) Communication port: Dual mode Bluetooth 3.0/4.0 BLE+EDR	
Servo parameters:	
1) Output torque: DC6.5V: 8kg · cm, DC8.5V: 12 kg · cm	
2) Running speed: DC6.5V: 0.238S/60° , DC8.5V: 0.198S/60°	
Working temperature:	-5°C ~ 85°C

User manual



Download cable

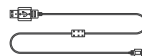

Charger or adapter

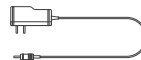

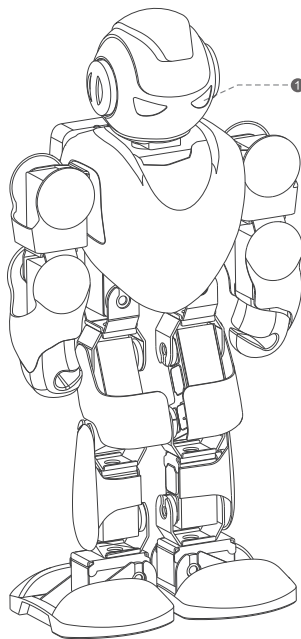

Front view

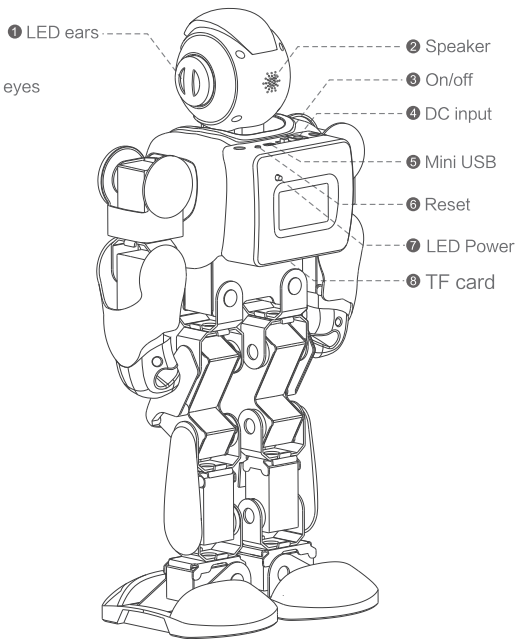

Rear view

① LED ears

① LED eyes

② Speaker

③ On/off

④ DC input

⑤ Mini USB

⑥ Reset

⑦ LED Power

⑧ TF card



## 02

## Parts and Components

**Controller** The mainboard is stored in Alpha's chest with operation buttons on his back. The mainboard serves as his brain, which controls and coordinates all his joints allowing them to move simultaneously.

The human-robot interaction is done through the control panel on the mainboard, which contains an external power interface, a power switch, a USB port, and a "Reset /Start" button. Their positions are shown below.

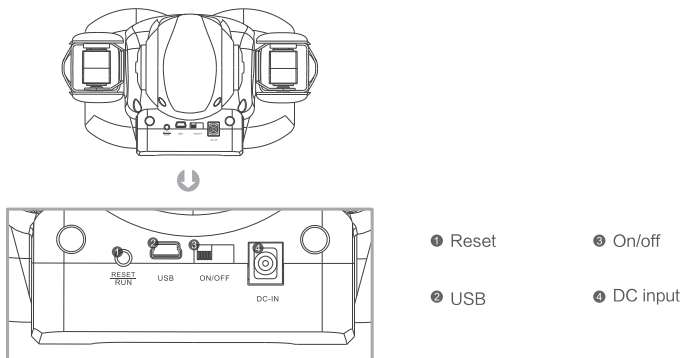

- Servo Actuator** The Alpha series contains a number of servo actuators. Each actuator has a fixed identification number (ID). The ID of the corresponding joints is shown in the following diagram and operating the corresponding servo will control the angle and speed of Alpha's joints.
- Battery** The battery is located in Alpha's abdomen. It is a special large-capacity li-ion battery with a built-in over-charge and over-discharge protection circuit.
- Charging** Before using Alpha, make sure is fully charged. Insert one end of the adapter to the charging port labeled "DC-IN" and connect the other to a 220V /110V AC power socket. When the charging indicator turns red, it indicates that Alpha is being charged. When charging is completed, the indicator will turn green, which indicates that the battery is fully charged. Please pull the adapter out of the charging port. Alpha can be debugged when charging.

## 02

## Parts and Components

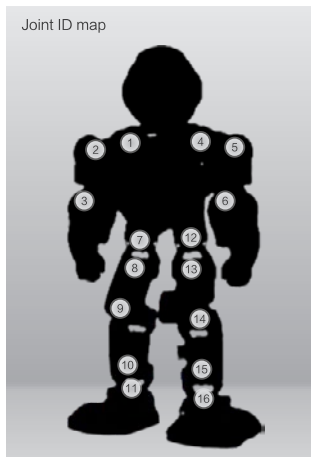
**Accessory  
Charger**

- Equipped with a built-in 7.4V battery that is not detachable and irreplaceable. If damaged, please contact our Customer Service Department for repairs.
- The charger should be used by an adult or under adult supervision.
- Regularly check the charger wire, plug, housing, and other components for damage. If damage is found, please discontinue use until repaired or replaced.
- The charger is not a toy, and Alpha is only compatible with the recommended charger (100V–240 V input, 9.6V 2A output).

02

## Parts and Components

- You may use a damp cloth to wipe the surface of Alpha. Please disconnect him from the charger before cleaning.
- 1) Please ask an adult to assist you when opening the package.
  - 2) This product cannot be heated. Please keep Alpha away from any open flame.

## Chapter IV. Operating Alpha

By switching power to "On", Alpha's LED eyes will turn blue. This indicates that he is in his standby state. Press "Reset/Start" and Alpha will enter his reset position, which is with his feet together and arms stretched out (as shown below). As the reset position requires large movements, please hold his backpack when resetting to prevent him from falling down. Alpha's joints are locked when in use. Therefore, do not force or press his joints for this will cause damage. By pressing "Reset/Start" once again, Alpha will initialize his introduction program, which includes introducing himself, singing, dancing, performing Kung Fu, etc.

### Reset position

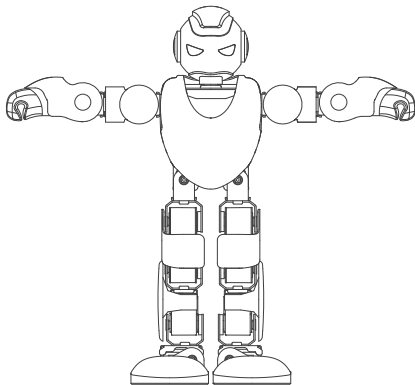

Front view

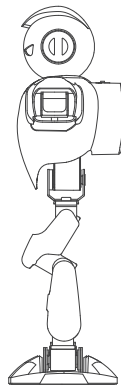

Side view

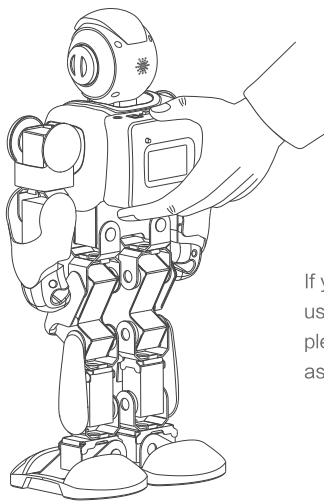

If you wish to pick up Alpha while using him or you wish to reset him, please pick him up by his backpack as to avoid damage.

- ! Note** Before pressing "Reset/Start", please keep Alpha away from your face and eyes. In addition, do not insert your fingers or any other objects into Alpha's joints. Please shut off the power immediately when he is not in his normal operating state. In addition, do not place Alpha on the edge of anything high as to prevent him from falling down and being damaged.

**Problem 1:** The control software does not run normally.

**Reason 1.** The software driven environment is not installed properly, Please download from our website and reinstall the software and software-driven environment .NET Framework 3.5.

**Reason 2.** There is a computer system error. Please restart your computer.

**Problem 2:** When starting Alpha, the connection to the computer is abnormal.

**Reason 1.** Alpha is missing a CP210X driver. Please download the appropriate driver from our website and install it.

**Reason 2.** Alpha's download cable interface is poorly connected. Please re-insert or replace the USB cable.

**Problem 3:** Alpha cannot reset after being started.

**Reason 1.** The voltage of the battery is low. Please charge it.

**Reason 2.** Some of the servo cables have become loose or have short-circuited. Please check whether servo cables are properly connected or are still functional.

**Problem 4:** When the robot is reset, some of the joints cannot work?

**Reason 1.** Some of servo wires are loose or have short-circuited, check whether the servo cables are properly connected or still functional.

## 04

# Troubleshooting

**Problem 5:** When Alpha is connected to a computer, she cannot be controlled or cannot download programs.

**Reason 1.** Alpha's download cable interface is poorly connected. Please re-insert or replace the USB cable.

**Reason 2.** Alpha's program has crashed. Please restart the robot and download again.

**Reason 3.** The battery voltage is low. Please charge it.

**Problem 6:** After downloading a program, Alpha does not work properly.

**Reason 1.** The battery voltage is low. Please charge it.

**Reason 2.** Some of servo cables are loose or have short-circuited. Check whether the servo cables are properly connected or still functional.

**Reason 3.** There is a problem with the program's syntax.

**Problem 7:** Your smart phone cannot control the robot.

**Reason 1.** Please reboot your smart phone and reconnect.

**Reason 2.** Connect the robot again.



## 04

# Troubleshooting

**Problem 8:** Your smart phone cannot connect with robot.

**Reason 1.** Robot is not powered on.

**Reason 2.** There are several robots. The smart phone connected with other robots, Please check the mac address of your robot and the robot which was connect.

**Reason 3.** The distance between your phone and Alpha is too far.

**Problem 9:** Alpha's dance is unstable.

**Reason 1.** The offset value of the servo joints was not set. Please refer to the software user manual which can be downloaded from our website and get to know how to set the offset value.

**Reason 2.** There is not enough power.

**Reason 3.** The servo is aging and needs to be replaced. Servos are consumables and are worn down over time. The gap between gears will increase with age. Therefore, the servos may need to be replaced.

**Problem 10:** Cannot enter the action list UI when connected to the robot.

**Reason 1.** There is no SD card inside of the robot.

**Reason 2.** SD card is experiencing contact failure.

**Reason 3.** There is a problem with the servo cables.



# Guarantee

[www.ubtrobot.com](http://www.ubtrobot.com)

User File

Product model

Product series no

User name

Date of purchase

Contact

User File

Warranty date	Description of failure and resolution method	Completion date	Consumer signature



# Warranty Terms

I. Please carefully fill out this card after purchasing Alpha. Read the following warranty terms carefully to ensure the product warranty is not invalidated.

1. Please keep this card in a safe place when purchasing products, and ask for the seller's stamp for confirmation.
2. The warranty card is required when requesting service repairs.
3. Please ensure that the warranty card information is true; otherwise, it is invalid.
4. The product warranty period is one year (except for consumables such as servos, the battery, and cables). Consumers have the right to receive a free repair service within one year from the purchase date in case of product failure. However, if the product failure occurs due to a natural disaster or by the fault of the consumer, the free repair service will not apply even within the one year and the consumer will be charged an appropriate repair service fee.

II. Consumers will be charged for the services rendered even within the one-year period under the following circumstances.

1. Failure caused by not following product instructions.
2. Failure due to mishandling by the consumer including, but not limited to:
  - Failure due to erratic power or faulty power supply;
  - Failure due to foreign matter inside the product;
  - Failure or damage due to external shock or from being dropped;
  - Damage or loose parts due to disassembly by the consumer;
  - External damage or deformity caused by corrosive liquid, paints, thinners, benzene, and etc.
  - Any other failure caused by an external event or mishandling by the consumer and not by the defect in the product;
  - Failure due to a natural disaster;
  - Exchange of normal consumable parts, such as the battery.
3. Failure caused by service not approved by the company, product modification, or broken product seal.
4. Aging, dents, or scratches on the surface of the product.

III. When the warranty period expires, the Company will still provide repair service, subject to an appropriate fee.

